

DRUM FILTERS ARE AVAILABLE IN VARIOUS SIZES WHICH ALLOWS FOR OPTIMAL ADAPTATION TO SPECIFIC FILTRATION REQUIREMENTS

ULTRAAQUA
SUB5™
SCREEN
TECHNOLOGY

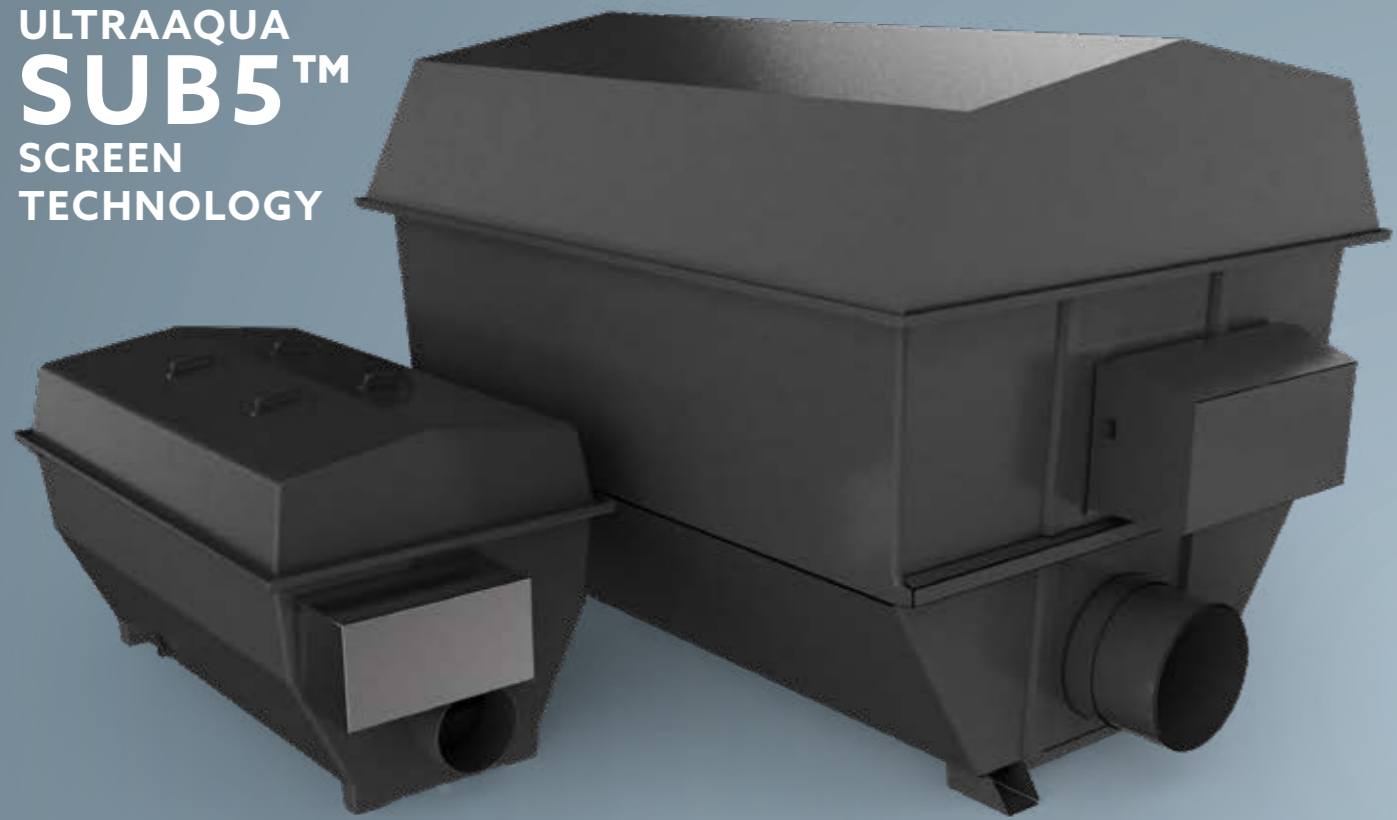

ROTARY MICRO SCREEN

WITH ULTRAAQUA SUB5™ SCREEN TECHNOLOGY

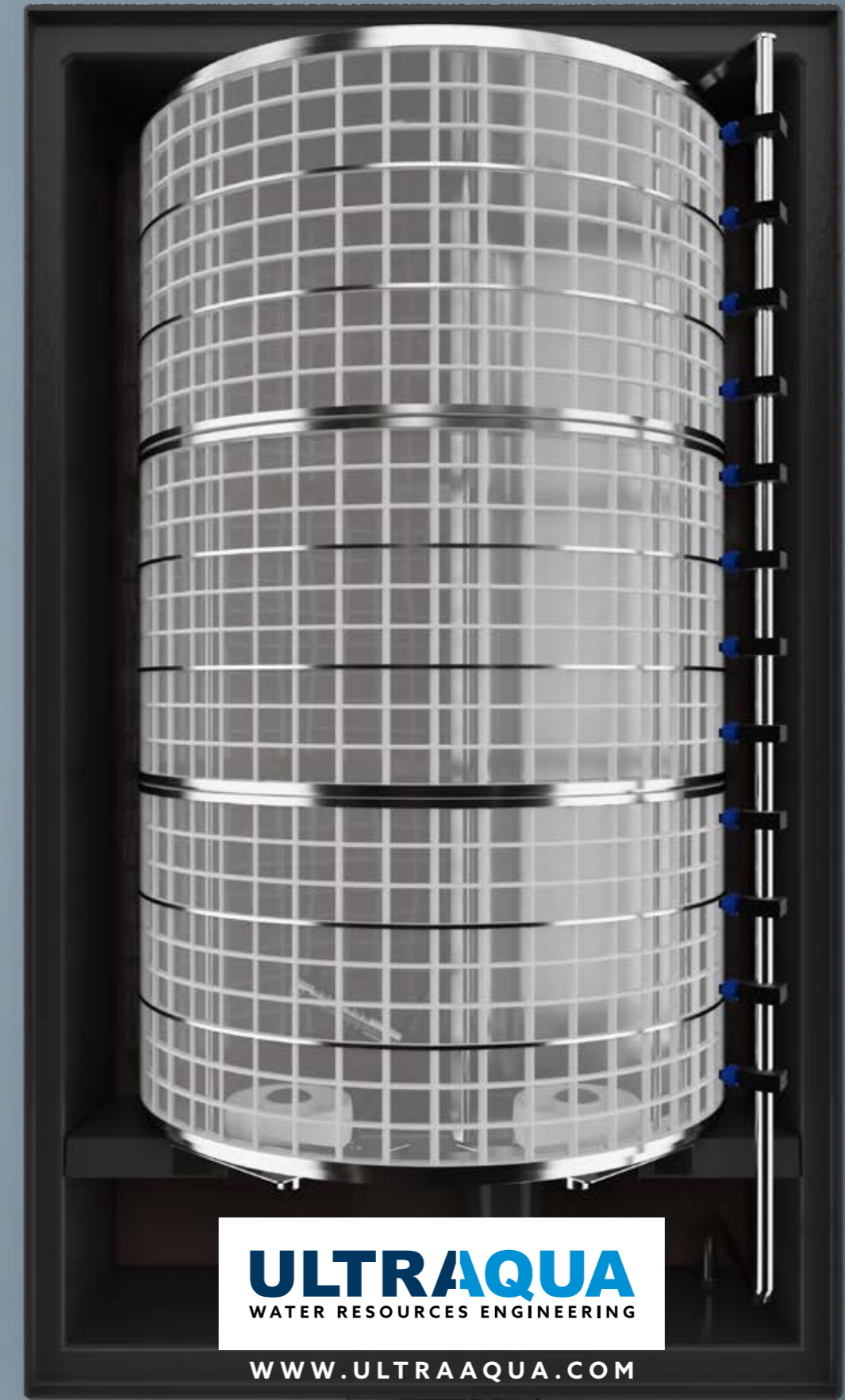

ULTRAAQUA
WATER RESOURCES ENGINEERING

WWW.ULTRAAQUA.COM

EFFICIENCY SUB5™ SCREENS

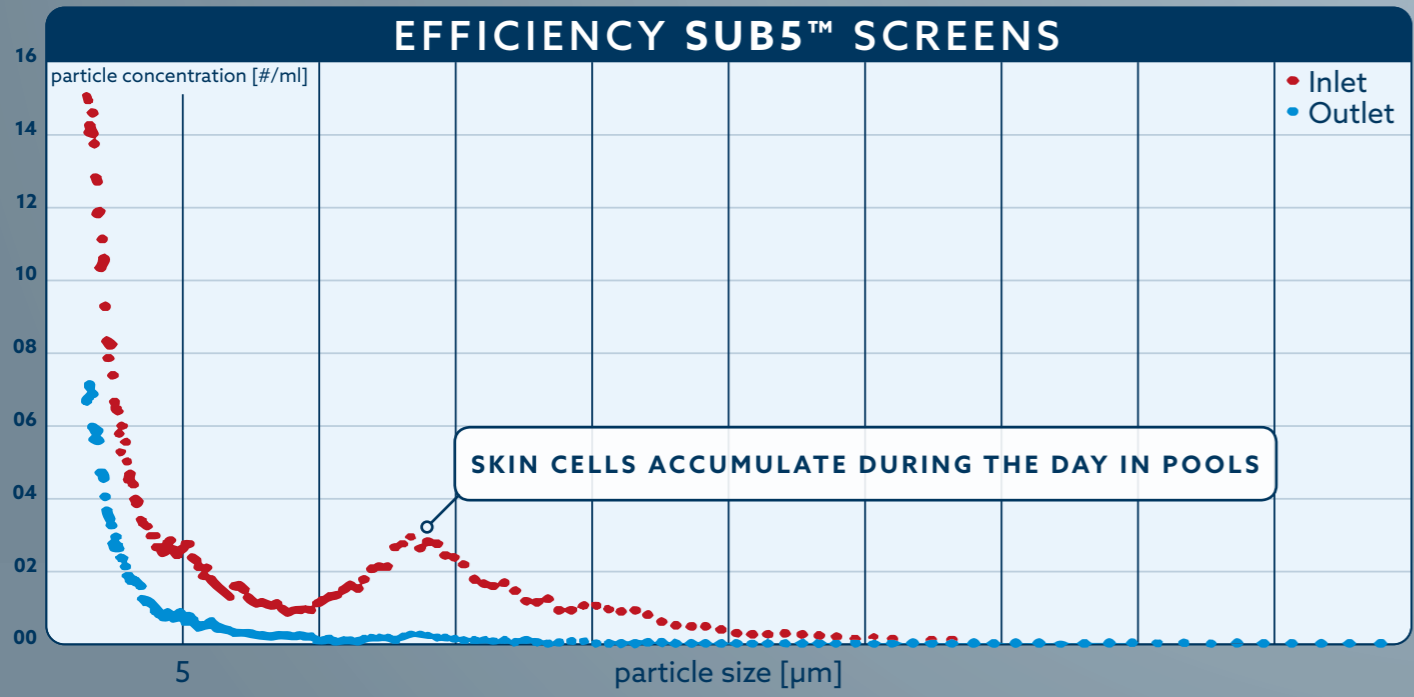

THE INNER WORKINGS OF A ROTARY MICRO SCREEN

ULTRAAQUA SUB5™ SCREEN TECHNOLOGY

New micro-screen technology using new filter cloth material for efficient pool water filtration

93% PARTICLE MASS SEPARATION

COMPETITIVE INVESTMENT AND OPERATION

High pressure nozzles active during backwash

PLC CONTROL

- Level controlled system
- Alarms for high water level
- Backwash alarm with monitoring and user controlled alarms for number of backwash



Leightweight plastic lid easy to open and remove

Presurized, filtered pool water 2-10 Liter per backwash dependent on filler size

Hair, skin cells and other particles to sewer in concentrated stream

WATER INTAKE

Drumfilter only operates at a pressure loss of about 10-40cm while a traditional sandfilter operates at a pressure loss of 3-8 meters

WATER OUTLET

Filtered water is returned to pool

Filter Port for drainage and filtered water for backwash pump

BASED ON A DECADE OF ENGINEERING ULTRAAQUA HAS DEVELOPED A DEDICATED MICROSCREEN WITH SUB5™ SCREEN TECHNOLOGY FOR OPTIMAL FILTRATION OF WATER FROM POOLS

GREATLY REDUCE ENERGY CONSUMPTION FOR FILTRATION OF POOL WATER

- Reduce backwash water consumption by apx. 50%
- Reduce energy consumption by apx. 50% through reduced head and heat loss

